



Key Benefits

- ▶ 2U 22" short depth design
- ▶ Light weight only 42.7 lbs / 19.4 kgs
- ▶ Rugged construction for mobility & durability
- ▶ Built-in solid bearing slide rails
- ▶ Built-in dual stereo speaker (per display)
- ▶ Three LED backlit display selections (4K, FHD, 4:3)
- ▶ DVI-D + VGA video input for FHD & 4:3 (per display)
- ▶ Display port 1.2 video input for 4K (per display)
- ▶ Fits 24" ~ 36" rack via adjustable mounting brackets
- ▶ 2-year standard warranty (upgradable up to 5 years)

Options

- DC power : 24V / 48V / 125V / 250V
- 3G / HD / SD-SDI Broadcast-grade input
- Sunlight readable 17" FHD display
- HDMI video input

The MRP 2U dual or triple display drawer is designed for Command and Control Systems which demand quick deployment for multi-faceted displays.

2U 22" depth platform allows for small size and transit case portability. To ensure chassis ruggedness, mobility and quality, as well as being suitable for harsh environment applications, the MRK drawer is meticulously constructed by a team of experts in our own CNC facilities for such applications.

The key benefit of the MRP series is the choice of different resolution panels available, including 4K 17", FHD 17", and 19" 4:3 LED backlit displays. Sunlight Readable FHD 17" LCD is also available. 4K 17" displays satisfy the increasing demand for superior graphics and image clarity.

Models



LH mounted



RH mounted

4K 17" Display

3840 x 2160 native resolution / Display port 1.2 video input
1920 x 1080 & 1920 x 1200 resolution support

MRP-K17-3 : Triple display drawer

MRP-K17-2L : Dual display drawer (LH mounted)

MRP-K17-2R : Dual display drawer (RH mounted)

1080p Full HD FHD 17" Display

1920 x 1080 native resolution / DVI-D + VGA video input

MRP-F17-3 : Triple display drawer

MRP-F17-2L : Dual display drawer (LH mounted)

MRP-F17-2R : Dual display drawer (RH mounted)

19" 4:3 Display

1280 x 1024 native resolution / DVI-D + VGA video input

MRP-19-3 : Triple display drawer

MRP-19-2L : Dual display drawer (LH mounted)

MRP-19-2R : Dual display drawer (RH mounted)

Product Specifications

LCD Panel	MRP-K17	MRP-F17	MRP-19
Native resolution	3840 x 2160	1920 x 1080	1280 x 1024
Panel size (diagonal)	17.3"	17.3"	19"
Brightness (cd/m²)	300	400	250
Contrast ratio (typ.)	1000 : 1	600 : 1	1000 : 1
Colors	16.7 M, 8-bit	16.7 M, 8-bit	16.7 M
Viewing angle (L/R/U/D)	89/89/89/89	80/80/60/80	85/85/80/80
Response time (ms)	Max. 30	40	5
Dot pitch (mm)	0.0995	0.1989	0.294
Display area (mm)	382.12H x 214.94V	381.888H x 214.812V	337.92H x 270.33V
Surface treatment	Anti-glare	Anti-glare, Hard-coating	Haze 25%, Hard-coating
Surface hardness	3H	3H	3H
Backlight type	LED	LED	LED
MTBF (hrs)	20,000	50,000	30,000

Video	MRP-K17	MRP-F17	MRP-19
Package	DP 1.2 / HDCP 1.3	DVI-D + VGA	DVI-D + VGA
Option	HDMI 2.0 / HDCP 2.2	HDMI 1.3 / HDCP 1.3	HDMI 1.2 / HDCP 1.1

Power	MRP-K17	MRP-F17	MRP-19
Input	Auto-sensing 100 to 240VAC, 50 / 60Hz		
Consumption	Screen on	Max. 29W	Max. 25W
	Power saving	Max. 9W	Max. 4W
	Power button on	Max. 2W	Max. 1W

Physical			
Product (W x D x H)	MRP-K17 /	mm	441.6 x 550 x 88
	MRP-F17	inch	17.4 x 21.7 x 3.5
	MRP-19	mm	441.6 x 600 x 88
		inch	22.8 x 23.6 x 7.8
Packing (W x D x H)		mm	580 x 683 x 197
		inch	22.8 x 26.9 x 7.8
Net Weight	MRP-K17 /	Triple display	24.1 kg / 53 lb
	MRP-F17	Dual display	19.4 kg / 42.7 lb
	MRP-19	Triple display	25.1 kg / 55.2 lb
		Dual display	20.4 kg / 44.9 lb
Gross Weight	MRP-K17 /	Triple display	29.3 kg / 64.5 lb
	MRP-F17	Dual display	24.2 kg / 53.2 lb
	MRP-19	Triple display	30.3 kg / 66.7 lb
		Dual display	25.2 kg / 55.4 lb
Chassis color		Dark	
Chassis materials		Steel	

Compliance	
EMC	FCC & CE certified
Safety	CE / LVD certified
Environment	RoHS2 & REACH compliant

Environment	
Operating temp.	0 to 55°C degree
Storage temp.	-20 to 60°C degree
Operating humidity	20~90%, non-condensing
Storage humidity	5 ~90%, non-condensing
Operating altitude	16,000 ft
Non-operating altitude	40,000 ft
Shock	10G acceleration (11ms duration)
Vibration	10~300Hz 0.5G RMS random vibration

Diagrams (mm)

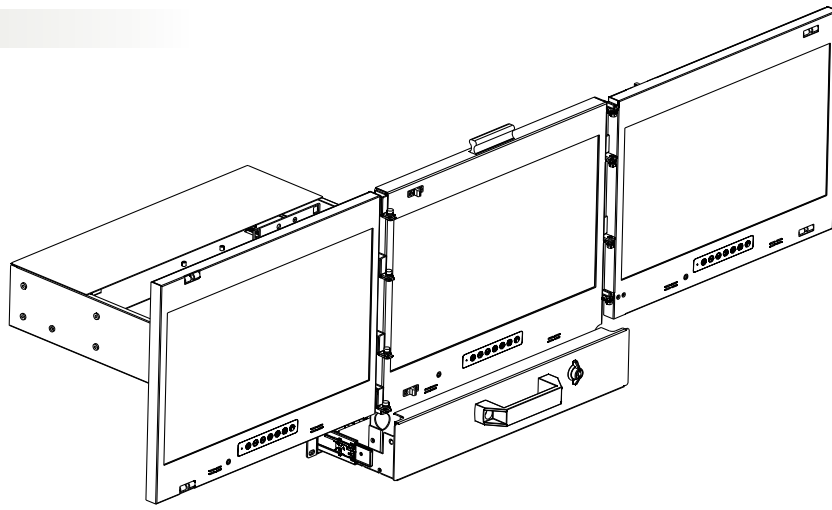

Front View

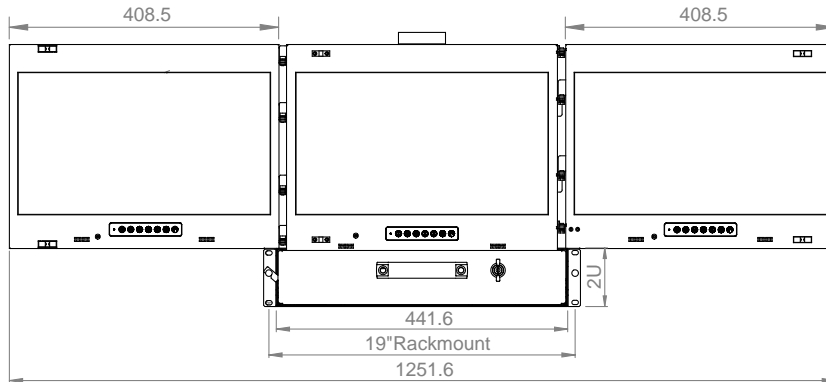

Side View

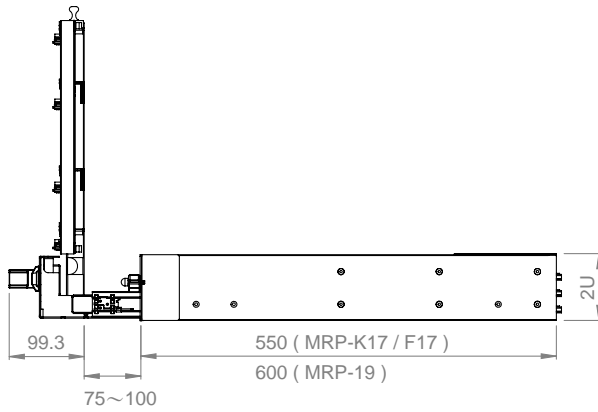

Top View

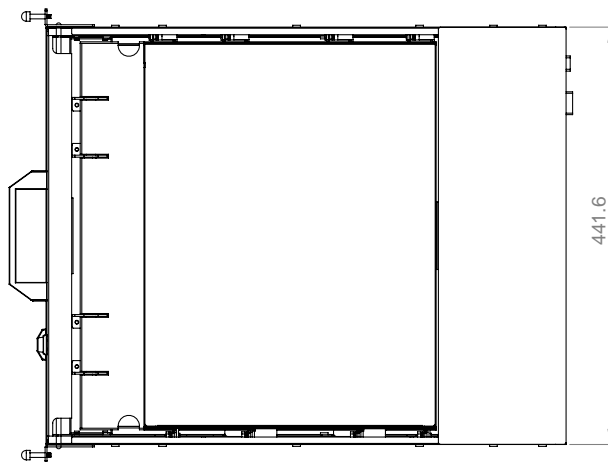

Rear View

MRP-K17

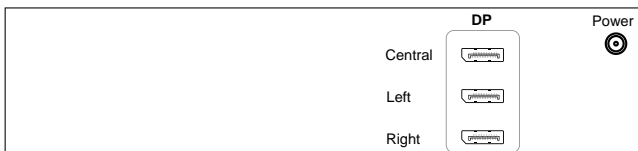

MRP-F17 / MRP-19

